

## High-Voltage Power Measurement

### WLTP Power Measurement of Electric and Hybrid Vehicles

For the approval to sell and register new passenger cars, the consumption values must be specified in accordance with the new Worldwide Harmonized Light-Duty Vehicles Test Procedure (WLTP). This also applies to pure electric vehicles and plug-in hybrids. For the determination of the range per charge, the electrical energy consumed on the test bench must be measured according to the drive cycles defined in the WLTP. In addition, the vehicle manufacturers must measure the energy losses and the performance profile to analyze the overall vehicle performance. For this purpose, the Vector CSM E-Mobility Measurement System is used online during both the charging process and test drive cycles. This new measurement system provides a simplified hardware and software for vehicle performance and efficiency analyses.

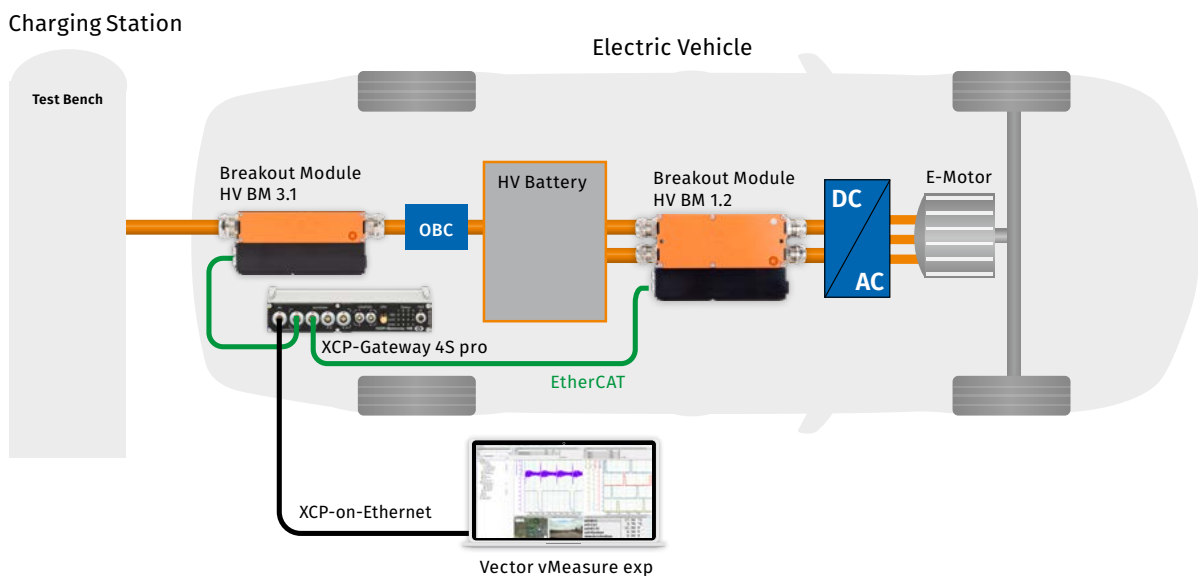

Fig. 1: Measurement of the electrical energy supply according to WLTP with the Vector CSM E-Mobility Measurement System on a test bench

### Background

The WLTP test cycles are started with a fully charged battery. Each drive cycle is carried out several times on the test bench until the battery is fully discharged. From this, the range of purely electric propulsion is determined. For plug-in hybrid vehicles, the electric range is determined in relation

to the total range. For this purpose, the last drive cycle with an empty battery is finished. The vehicle is then fully charged again and the energy flow into the vehicle is measured. The amount of energy consumed for charging and the range driven result in the energy requirement stated as kWh/100 km.



## Challenge

 Figure 2 shows the battery Voltage (U), the Current (I) and the speed (v) measured during several repeated drive cycles for a plug-in hybrid vehicle. The first test cycle was carried out during purely electrical propulsion. The battery was discharged at the end of the second cycle. Finally, the last repetition was carried out with an empty battery. The voltage of the fully charged battery decreases during the initial run from 405 V to 353 V and recovers only to 355 V in the last run due to regeneration. The current signal shows that at times almost 200 A were reached in the "extra high" part. The regeneration can easily be detected by negative currents. One challenge is that the raw values do not allow direct determination of electric power consumption. The measurement data must be used to calculate the consumed energy according to the speed, ideally in real time for continuous monitoring. Therefore the data must also be available with high resolution.

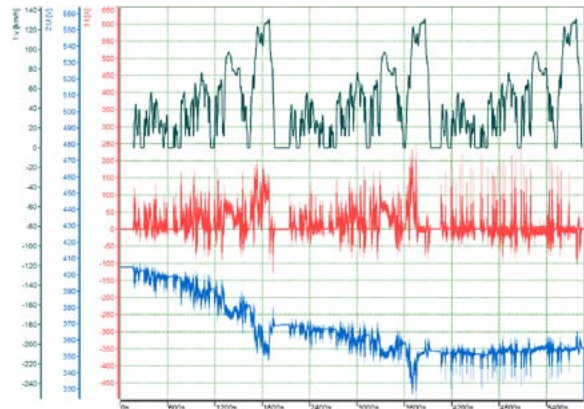



Fig. 2: Battery voltage U (blue), current I (red) and WLTP speed profile (green) for the class-3 driving cycle

## The CSM Vector Measuring Solution

 The solution is the Vector CSM E-Mobility Measurement System: a perfectly matched toolchain consisting of HV-safe measurement modules, ECU measurement technology and a software tool for synchronized online data acquisition and data analysis for test bench and road tests.

For WLTP test measurement, CSM High-Voltage Breakout Modules (HV BM) are installed directly onto the high-voltage power cables (Fig. 1). One is in front of the charger and another after the battery. The current and voltage can be measured synchronously with a high sampling rate of up to 1 MS/s. CSM's HV-Breakout Modules have been specially developed for distributed and safe measurement applications on high-voltage cables. The special HV BM Shunts are permanently installed and are available in various options with rated current range from 50 A to 800 A.

With the Vector eMobilityAnalyzer software, the energy is calculated in real time during the test cycle drive and during the charging process from the variables measured by the breakout modules. In this

case, the DCAnalysis function of the eMobilityAnalyzer of vMeasure exp is very useful. In addition to the fast ripples of voltage and current, this function determines the working power P [unit W or kW] and the cumulative consumption W [unit Wh or kWh]. If the losses from the charging process are also to be determined, the function 'ChargerEfficiencyAnalysis' is suitable for this purpose. It determines the power recorded and supplied by the on-board charger, the accumulated electrical power of the input and output and the efficiency of the charger.



Fig. 3: CSM High Voltage Breakout Module HV BM 1.2

Figure 4 shows the effective power (P) and the accumulated electrical consumption (W) for the measurement shown in Fig. 2. The power correlates with the acceleration of the drive cycle and contains consistently short peaks, both in motor and regeneration modes. The recorded actuation was up to 75 kW and the recuperation was only -38 kW. The first purely electric run was used to calculate a consumption of 5.14 kWh. This corresponds to approx. 22.1 kWh per 100 km. The second run could not be completed under pure electric propulsion and the energy consumption decreased accordingly to 4.04 kWh. In the last cycle, the battery was empty except for the energy recovered from the braking energy recovery system. The energy balance shows that the battery was charged at -0.13 kWh during the last run by recovery.

This example shows how the eMobilityAnalyzer software can efficiently determine the energy consumption of electric and plug-in hybrid vehicles. Due to the high sampling rate, short power pulses can also be detected, which leads to a more accurate

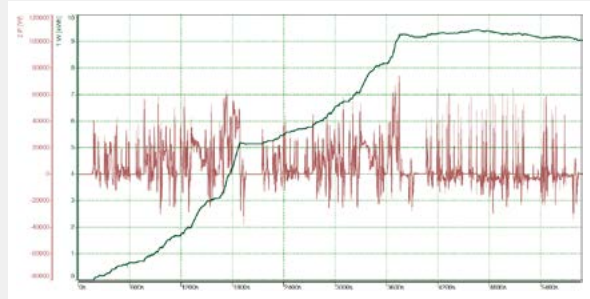

Fig. 4: Power P (red) and energy consumption W (green) of a plug-in hybrid vehicle according to WLTP drive cycles.

calculation of energy consumption and vehicle range under electric propulsion. A combination of different functions also makes it possible to examine the total energy flow from the power grid to the used battery power.

Since the measuring system is installed in the vehicle, the consumption measurement can then also be carried out for RDE (Real Driving Emissions) tests in real road traffic.

## Benefits

- ▶ Innovative, fast, accurate and flexible measurement for validation and verification of high-voltage electrical systems in the laboratory and in road tests.
- ▶ Like all measurement modules from CSM, the HV BM is small, robust and designed for direct assembly in the vehicle. This greatly simplifies the measurement system, and the vehicle does not need to be equipped with additional current sensors, long measuring cables and large measuring devices. This not only saves time and reduces the risk of measurement errors, but also shortens the measurement chain and improves the quality of the measurement.
- ▶ Synchronous recording of all signals; physical measurement, ECU signals, and vehicle bus signals.
- ▶ The performance of the eMobilityAnalyzer software makes it easy to perform complex mathematical operations on measurement channels in real time during measurement. Thus, in addition to the recording of the directly measured signals, filtered signals or the derivation of signals can be visualized and recorded synchronously. They can even act as a trigger signal.
- ▶ Users can easily and accurately measure the current and voltage dynamics in the on-board grid and On-board components, and receive instant feedback during lab and road tests, making verification and subsequent deeper analysis much more efficient.
- ▶ Seamless, automated analysis and presentation of the measurement data can be done with the Vector vSignalizer software.

## Featured Products

### HV Breakout Module - Type 1.2

CSM's HV Breakout Module (BM) Type 1.2 was designed for single-phase measurements of current, voltage and power. It is ideal for measurement on large consumers such as electric motors equipped with separate HV+ and HV- cables.



### HV Breakout Module - Type 3.1

CSM's HV Breakout Module (BM) Type 3.1 was developed for the three-phase determination of current, voltage and power on high-voltage carrying cables with currents up to  $\pm 32$  A. One module performs three-phase measurement, therefore offering enormous cost and space advantages.



### XCP-Gateway Series

CSM's XCP-Gateway Series protocol converters were specially developed for CSM EtherCAT® measurement modules and for measurement tasks with multiple measurement channels and high measurement data rates. The XCP-Gateway is available in "Basic" and "pro" versions. The "pro" version has two CAN interfaces via which CAN-based CSM measurement modules can be connected and integrated into the XCP-on-Ethernet measurement data protocol. In the "pro" version, temperature data from the HV Breakout Modules can also be transferred directly via EtherCAT®.



CSM provides you with comprehensive complete packages consisting of measuring modules, sensors, connecting cables and software - customized to your individual needs.

Further information on our products are available on our website at [www.csm.de](http://www.csm.de) or via e-mail [sales@csm.de](mailto:sales@csm.de).



**CSM GmbH Headquarter** (Germany)

Raiffeisenstraße 36 • 70794 Filderstadt  
☎ +49 711-77 96 40 ✉ sales@csm.de

**CSM Office Southern Europe** (France, Italy)

Site d'Archamps  
178, rue des Frères Lumière • Immeuble Alliance – Entrée A  
74160 Archamps France  
☎ +33 450-95 86 44 ✉ info@csm-produits.fr

**CSM Products, Inc. USA** (USA, Canada, Mexico)

1920 Opdyke Court, Suite 200 • Auburn Hills, MI 48326  
☎ +1 248 836-4995 ✉ sales@csmproductsinc.com

**CSM** (ROW)

Vector Informatik (China, Japan, Korea, India, Great Britain)  
ECM AB (Sweden)  
DATRON-TECHNOLOGY (Slovakia, Czech Republic)

Our partners guarantee you worldwide availability.  
Feel free to contact us.