



# HV Breakout Module

## Type 1.2+S



### Product description

The **HV Breakout Modules (BM) 1.2+S** have been specifically designed by CSM for measuring the inner conductor current, shield current and the voltage in a HV vehicle electrical system (DC) simultaneously.

The two shielded HV power cables are fed via cable glands into the **HV BM 1.2+S** where they are connected. A typical application is the measurement of current between the HV battery and inverter, where higher frequency components occur as a result of clocking.

The voltage is measured directly. The current measurements are performed by using shunt modules, which include a temperature sensor and memory for calibration data for automatic online temperature compensation.

The **HV BM 1.2+S** outputs the measured data with a maximum data rate of up to 1MHz via EtherCAT® interface and simultaneously with a data rate of up to 10 kHz via the additional CAN interface. This allows high speed data acquisition via Ethernet and data recording via CAN at the same time.

The calculated quantities are available (with the option "Calc." enabled) and are sent on the CAN bus with a transmission rate of up to 100 Hz.

### Maintenance

- ▶ HV isolation at least every 12 months, scope of testing according to EN 61010
- ▶ Calibration every 12 months recommended

### EtherCAT CAN ⚡ Key features

- ▶ Single-phase measurement of voltage (U), current (I) and shield current (I) in HV applications, HV-safe enclosed for:
  - ▶ Nominal voltages up to  $\pm 1,000V$  (measurement range up to  $\pm 2,000V$ )
  - ▶ Currents up to  $\pm 2,000A$  (Peak)
  - ▶ Shield currents up to  $\pm 500A$  (Peak)
- ▶ Output of voltage, current and shield current with up to 1MHz measurement data rate
- ▶ Output of RMS values  $U_{rms}$  and  $I_{rms}$ , active power, apparent power, reactive power and power factor  $\lambda$
- ▶ Simultaneous EtherCAT® and CAN bus communication

### Scope of delivery

- ▶ HV Breakout Module 1.2+S
- ▶ Configuration software CSMconfig
- ▶ Documentation
- ▶ Device Description File (\*.xml)
- ▶ Calibration certificates for I and U in accordance with DIN EN ISO/IEC 17025
- ▶ HV isolation test protocol

### Accessories

- ▶ See datasheets "XCP/ECAT Accessories" and "CAN Accessories"

## Technical Data

<b>Type designation</b>	<b>HV BM 1.2+S</b>
<b>Technical data valid as of revision</b>	C030
<b>Input<sup>1</sup> in</b>	separate HV power cables for HV+ and HV-
Number of measured phases	1
Number of cable glands	2 per side
Inner conductor cross section	16 mm <sup>2</sup> up to 95 mm <sup>2</sup>
Cable outer diameter <sup>2</sup>	9 mm up to 25 mm (select the appropriate cable gland) <a href="#">See section "Cable glands"</a>
<b>Measurement signals</b>	voltage, current, shield current and instantaneous power
<b>Measurement ranges</b>	
Voltage	±100, ±200, ±500, ±1,000, ±2,000 V <sup>3</sup>
Inner conductor current, shield current	4 configurable measurement ranges ( $I_{meas}$ ) depending on mounted shunt module $I_1 = I_{peak}, I_2 = I_{rated}, I_3, I_4$ <a href="#">See section "Shunt modules"</a>
Internal resolution	16 bit
Internal sampling rate	1 MS/s
Calculation of instantaneous power	permanently online with 1 MHz
<b>Measurement data rate/ sending rate</b>	
ECAT <sup>4</sup>	1, 2, 5, 10, 20, 50, 100, 200, 500, 1,000 kHz
CAN <sup>5</sup>	1, 2, 5, 10, 20, 50, 100, 200, 500 Hz, 1, 2, 5, 10 kHz
HW input filter	8 <sup>th</sup> order Bessel low-pass-filter, cutoff frequency approx. 250 kHz
SW filter	
ECAT	<ul style="list-style-type: none"> <li>▶ Off, only for sending rate of 1,000 kHz</li> </ul>
Options for SW filter, adjustable per channel	<ul style="list-style-type: none"> <li>▶ 6<sup>th</sup> order Butterworth low-pass-filter, range: 10 Hz to 200 kHz: <ul style="list-style-type: none"> <li>▶ automatically adjusted on sending rate or</li> <li>▶ user-selectable cutoff frequency</li> </ul> </li> </ul>
CAN	<ul style="list-style-type: none"> <li>▶ Off, only for sending rate of 10 kHz</li> </ul>
Options for SW filter, adjustable per channel	<ul style="list-style-type: none"> <li>▶ 6<sup>th</sup> order Butterworth low-pass-filter, range: 0.1 Hz to 2 kHz: <ul style="list-style-type: none"> <li>▶ automatically adjusted based on sending rate or</li> <li>▶ user-selectable cutoff frequency</li> </ul> </li> <li>▶ Average value per sending interval</li> </ul>
<b>Output signals</b>	
ECAT and CAN	voltage, current, shield current, instantaneous power, shunt temperatures, module temperature
CAN	Optionally calculated quantities: RMS values for voltage and inner conductor current, active power, apparent power, reactive power and power factor Lambda → Adjustable integration times 10 ms to 10 s

<b>Type designation</b>	<b>HV BM 1.2+S</b>
<b>Measurement deviation <sup>6</sup></b>	
Voltage (DC)	
Gain error at 25 °C <sup>7</sup>	typ. ±0.005 % of measured value max. ±0.05 % of measured value
Offset and scaling error <sup>7</sup>	typ. ±0.003 % of range max. ±0.02 % of range
Gain drift	max. ±20 ppm/K of measured value
Zero drift	max. ±10 ppm/K of range
Current (DC), shield current (DC)	online calculation with stored calibration data, with temperature compensation
Gain error at 25 °C <sup>7</sup>	for shunt module 50 A, 125 A, 250 A general: typ. ±0.03 %, max. ±0.15 % of measured value  for shunt module 500 A and 1,000 A up to 600 A: typ. ±0.05 %, max. ±0.15 % of measured value up to 750 A: typ. ±0.25 %, max. ±0.3 % of measured value above 750 A: typ. ±0.3 %, max. ±0.4 % of measured value
Offset and scaling error <sup>7</sup>	typ. ±0.02 % of range (valid for all shunt modules) max. ±0.05 % of range
Gain drift	max. ±25 ppm/K of measured value
Zero drift	max. ±15 ppm/K of range
<b>Fields of application <sup>1</sup></b>	for measurements in HV environments <sup>8</sup>
Nominal voltages (unipolar & bipolar)	up to ±1,000 V
<b>Routine test</b>	HV isolation test according to EN 61010-1
<b>EtherCAT® interface</b>	Ethernet 100 Base-TX, 100 Mbit/s, EtherCAT® slave controller, synchronization via Distributed Clocks or Sync Manager 3
Configuration	with configuration software CSMconfig via XCP-Gateway or EtherCAT® master software via CANopen over EtherCAT® (CoE), settings and configurations permanently stored in the module
<b>CAN interface</b>	CAN 2.0B (active), High Speed (ISO 11898-2:2016), 125 kbit/s to max. 1 Mbit/s, up to 2 Mbit/s, data transfer free running
Configuration	via CAN bus using CSMconfig, settings and configurations permanently stored in the module
<b>LED indicators</b>	
ECAT	Status, Link Activity IN, Link Activity OUT
CAN	Power, Status
Measurement channel	Configuration, Operation

<b>Type designation</b>	<b>HV BM 1.2+S</b>
<b>Measurement categories<sup>9</sup></b>	
CAT 0	1,000V DC
CAT II	600V
CAT III	300V
<b>Power supply</b>	
Minimum	7V DC (-10 %)
Maximum	30V DC (+10 %)
Power consumption	typ. 3W
<b>Housing</b>	aluminum with HV designation (RAL 2003)
Protection class <sup>10</sup>	IP67
Ground connection	M8 threaded hole
Weight (device)	approx. 2,500g (incl. shunt modules, without cable glands)
Dimensions (w × h × d)	approx. 240 × 46 × 191,5mm (without cable glands)
<b>Connectors</b>	
EtherCAT®IN	LEMO 1B, 8-pole, code L
EtherCAT®OUT	LEMO 1B, 8-pole, code A
CAN <sup>11</sup>	LEMO 0B, 5-pole, code G
<b>Operating and storage conditions</b>	
Operating temperature range	-40 °C to +120 °C
Relative humidity	5 % to 95 % (non-condensing)
Operating altitude	max. 5,000 m above sea level (CAT 0) max. 3,000 m above sea level (CAT II and CAT III)
Pollution degree <sup>10</sup>	4
Storage temperature	-40 °C to +125 °C
<b>Conformity</b>	
<b>Device safety</b>	EN 61010-1:2010 + A1:2019 + A1:2019/AC:2019 with EN IEC 61010-2-030:2021 + A11:2021

<sup>1</sup> Please read the CSM document "Safety Instructions HV Breakout Module".

<sup>2</sup> Cable glands and shunt modules are selected separately.

<sup>3</sup> The measurement ranges of the analog inputs are dimensioned for ±2,000V for acquiring transient overvoltages.

<sup>4</sup> All measurement data rates are configurable via XCP-Gateway. When configuring via a standard EtherCAT® master, a maximum measurement data rate of 10 kHz/channel is supported.

<sup>5</sup> In order to be able to use a measurement data rate of 10 kHz for all measurement signals, a CAN interface with 2Mbit/s is required.

<sup>6</sup> The values for current differ depending on the frequency. Further information can be found in the Technical Information document on the subject of "Deviation of Measurement".

<sup>7</sup> The typical value is based on a statistically relevant number of calibrations. It is defined as the limit value below which 70% of all measured deviations lie.

<sup>8</sup> According to EN 61010-1:2010 + A1:2019 + A1:2019/AC:2019 with EN IEC 61010-2-030:2021 + A11:2021





<sup>9</sup> Further information can be found in the Technical Information document "Measurement Categories for CSM HV Measurement Modules".

<sup>10</sup> Only if installed correctly. Please follow the assembly instructions in the installation manual.

<sup>11</sup> Optionally available in other variants.

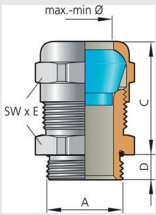
## Cable glands

Depending on the cable outer diameters, different cable glands must be adapted to the **HV BM 1.2+S**. Only suitable combinations (cables + cable glands) ensure the tightness of the housing. The cable glands are selected separately. The following types are currently available:<sup>1</sup>

Type	9/14	11/20	15/25
			
Cable outer diameter			
max. Ø	14 mm	20 mm	25 mm
min. Ø	9 mm	11 mm	15 mm

<sup>1</sup> Please regard technical information in "Cable catalog Cable glands" of the company Pflitsch.

## Shunt modules

For the **HV BM 1.2+S**, CSM offers shunt modules with different measurement ranges. The shunt modules are selected separately and are installed permanently. Shunt modules from  $\pm 50$  A up to  $\pm 250$  A are available for shield current measurements and shunt modules from  $\pm 50$  A up to  $\pm 1,000$  A are available for inner conductor current measurements. The maximum operating time depends, among other things, on the ambient temperature and the resulting power loss in the measurement module. The 1,000 A shunt module cannot be operated continuously at rated current. With the other shunt modules, the rated current may not be applied continuously under certain circumstances. The temperature of the shunt modules must not exceed  $+120^\circ\text{C}$

Measurement of	inner conductor current and shield current			only inner conductor current	
	$\pm 50$	$\pm 125$	$\pm 250$	$\pm 500$	$\pm 1,000$
Rated current $I_{\text{rated}}$ [A]	$\pm 50$	$\pm 125$	$\pm 250$	$\pm 500$	$\pm 1,000$
Peak current $I_{\text{peak}}$ [A]	$\pm 100$	$\pm 250$	$\pm 500$	$\pm 1,000$	$\pm 2,000$
Measurement ranges $I_1, I_2, I_3, I_4$ [A]	$\pm 100, \pm 50, \pm 25, \pm 10$	$\pm 250, \pm 125, \pm 50, \pm 25$	$\pm 500, \pm 250, \pm 125, \pm 50$	$\pm 1,000, \pm 500, \pm 250, \pm 125$	$\pm 2,000, \pm 1,000, \pm 500, \pm 250$
Resolution at $I_{\text{peak}}$ [mA/digit]	3	7	15	30	60
Resistance [ $\mu\Omega$ ]	500	200	100	50	35



**CSM GmbH**

Raiffeisenstr. 36  
70794 Filderstadt  
Germany

Technical Questions:  
**[www.csm.de/service-and-support](http://www.csm.de/service-and-support)**

Sales Contact:  
**[www.vector.com/contact](http://www.vector.com/contact)**

Part of the Vector Group



All trademarks mentioned are property of their respective owners.  
Specifications are subject to change without notice.  
CANopen® and CiA® are registered community trademarks of CAN in Automation e.V.  
EtherCAT® is registered trademark and patented technology,  
licensed by Beckhoff Automation GmbH, Germany.