

## High-Voltage Power Measurement

### Efficiency measurement of a high-voltage powertrain

The electric powertrain needs to be tested several times throughout the various development phases of modern electric vehicles. These phases include:

- ▶ the validation of new subsystems such as electric axles from external suppliers
- ▶ testing development levels and sub-components
- ▶ quality control and durability
- ▶ performance and benchmark tests

The following example shows how the efficiency of the powertrain is calculated with the Vector CSM E-Mobility Measurement System.

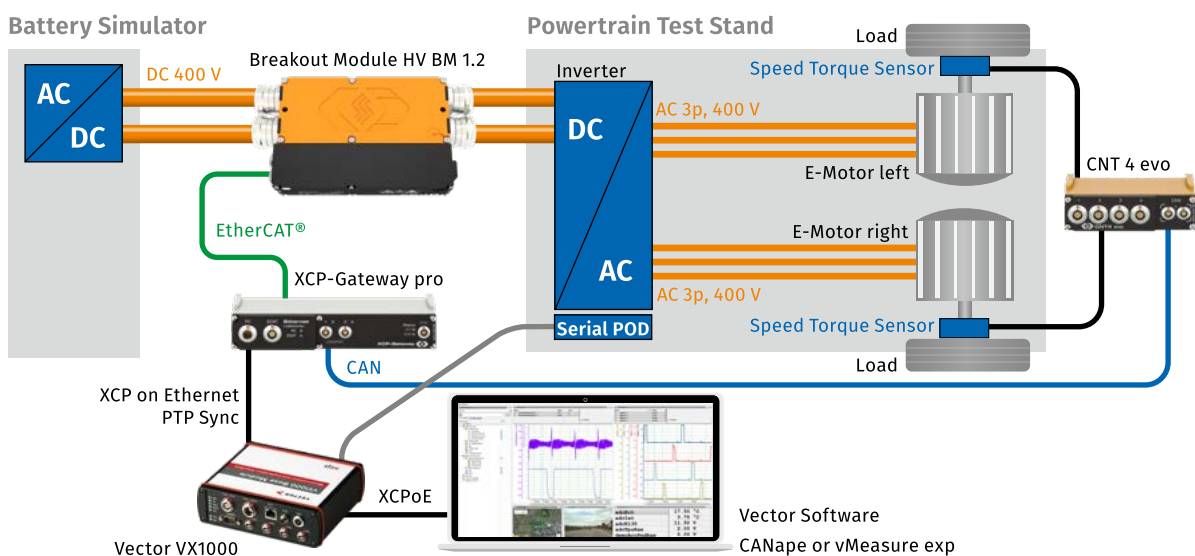

Fig. 1: Vector CSM E-Mobility Measurement System for efficiency analysis of a powertrain. The eMobilityAnalyzer for power analysis is an integral part of Vector CANape and vMeasure exp software.

### Background

Modern powertrains are fully integrated, which means that power cables between the individual components are often no longer accessible for measurement instrumentation. Direct measurements can only be made on the DC high-voltage battery connection. For this reason, the measurement of the system's overall efficiency is required for optimization. To calculate efficiency, only the ratio of mechanical output power to electrical input

power can be measured. To determine the efficiency map, load points are approached at which the power is measured. The characteristic maps provide information on the impact of software changes, new components or functional developments on the overall efficiency. This verifies whether the optimization goals have been achieved and can be used to verify and improve simulations.



## Challenge

 In this application, the customer's system consists of the electric drive unit with two 3-phase axle motors with a six-phase inverter (Figure 1). The challenges of this measurement task lie both in the measurement of the electrical power in the high-voltage cables between the battery simulator and the inverter, and the detection of the mechanical power at the output shafts. Because the multiple variables required to calculate power and efficiency are distributed throughout the powertrain, the measurement system must have data acquisition devices located near each sensor. For

example, the acquisition of the speed-torque sensor data must be done as close as possible to the measurement point to avoid electro-magnetic (EMC) interference. The fundamental challenges of powertrain optimization are the interaction of control variables with the accurate synchronization of physical measured values for real-time calculation of power and efficiency. The interaction of control variables, the synchronization of measured values, and the real-time calculation of power values is a fundamental challenge in test bench planning.

## The CSM Vector Measuring Solution

 The customer's implemented solution is the Vector CSM E-Mobility Measurement System: A set of coordinated measurement tools consisting of High Voltage (HV) safe Breakout Modules, CAN MiniModules, ECU measurement technology, and the vMeasure exp or CANape software tools.

The electrical input power is determined between the battery simulator and the inverter with a CSM HV Breakout Module (BM) 1.2. The module simultaneously measures voltage and current from 50 A to 800 A using the device under test's standard, separate cables for HV+ and HV-. The HV BM 1.2 and all CSM EtherCAT®-based modules have a measurement data rate of 1 MHz. The sampling values of voltage and current are output via high-speed EtherCAT® bus for power calculation within the Vector software.

The HV+ and HV- cables are either safely led into the encapsulated housing via cable glands and connected (HV BM 1.2) or directly connected to the Breakout Module via a PowerLok plug-in system (HV BM1.2 C). The HV BM 1.2 C is particularly suitable for quick changes, e.g. when different e-axes are tested on the test bench one after the other.

The measured values of the speed torque sensors for mechanical power are measured via CSM's CNT4 evo MiniModule, which provides measurement data via standard CAN bus.

Both measurement modules are connected to an XCP Gateway that converts the EtherCAT® and CAN signals into the standard XCP-on-Ethernet protocol as the interface to the Vector software.

The analysis of electrical and mechanical performance, as well as the efficiency calculation, is carried

out with the Vector vMeasure exp or CANape software. This software now includes the eMobilityAnalyzer library of functions, where power analyses can be carried out in real time on data from many channels.

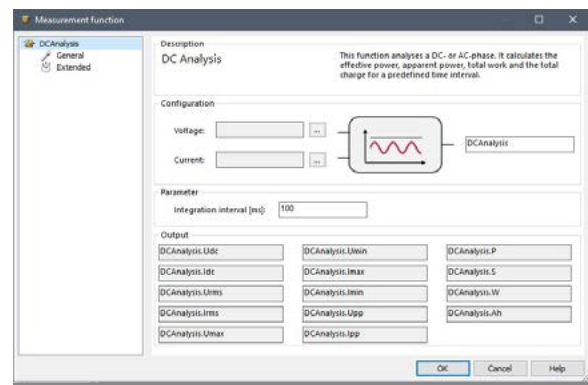

Fig. 2: The DC Analysis function for power analysis on a DC line. The input variables are the sampling values of voltage and current from the HV BM 1.2. The effective power, apparent power, total work, and total load are calculated from a predetermined equation.

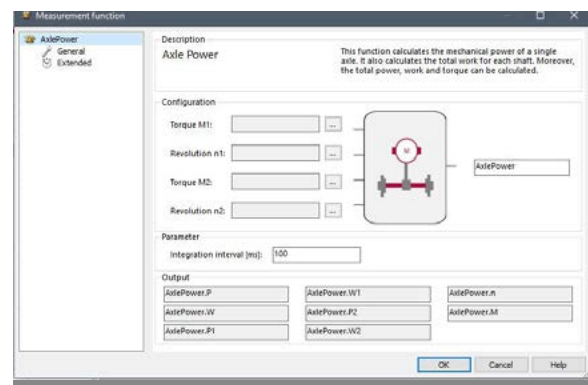

Fig. 3: The Axle Power function calculates the mechanical performance and total power from the signals of the speed torque sensors on the each of the two axes

Internal measurements of the powertrain from the electronic control unit (ECU) and the electric motor are recorded via the Vector VX1000 interface. This allows the internal measurement and control

variables of the test specimen to be directly correlated with the measured power values. All measurement data is synchronized via the IEEE standard for Precision Time Protocol (PTP).

## Benefits



The integrated Vector CSM measurement technology system allows for a simple, yet distributed measurement setup. A measurement rack with power analyzers, current migration system and transient recorder and their necessary long measurement cables is no longer needed. The resulting shorter measurement chain increases the quality of the data and simplifies the test setup.

Measurements with a Breakout Module installed directly in the high-voltage cables eliminates sources of error due to long sensor cables and interference from multiple devices in close proximity to each other, for example for current transformers. Furthermore, they are a safer alternative and meet DIN EN-61010 requirements.

Like all measurement modules from CSM, the Breakout Modules are compact, robust, and designed for direct instrumentation in the vehicle and test bench. CSM can supply Breakout Modules with pre-assembled HV cables and connectors for direct installation into your device under test. This “plug-and-play” setup also allows for rapid re-use of the modules and rapid turnaround of tests in your facility.

With the precise measurement data from CSM measurement modules, the eMobilityAnalyzer library from Vector calculates the electrical and mechanical power, as well as the efficiency in real time, with the highest accuracy. This allows the powertrain performance to be analyzed in detail.

The configuration of the test specimen and the acquisition of measurement data is carried out with only one comprehensive system. The complex connection of different measurement instruments to the test bench automation system is no longer necessary.

The scalability with additional sensors, for example for the high-voltage-safe measurement of temperatures inside the inverter, is easily feasible with CSM HV MiniModules. Sensors and modules for non-HV applications can also be added into this solution.

It is easy to apply the same measurement structure in the test vehicle for real-time powertrain measurement while driving on a test track or other scenario. In this way, data obtained on the test bench compared with the test vehicle on the road, thus a single solution can be used throughout all phases of the development cycle.

## Featured Products

### HV Breakout Module - Type 1.2

CSM's HV Breakout Module (BM) Type 1.2 was designed for single-phase measurements of current, voltage and power. It is ideal for measurement on large consumers such as electric motors equipped with separate HV+ and HV- cables.

The HV Breakout Module 1.2 is available in two versions for connection via cable glands or PL500 plug-in system (HV BM 1.2C).



### CNT4 evo

CSM's CNT4 evo is a high-precision measurement module for measuring frequencies up to 300 kHz, for determining duty cycles or PWM signals, for determining period and pulse duration as well as up and down counting. Speeds can be recorded directly in the module and output as a value on the CAN bus. In addition, the time offset between adjacent channels can be measured.



### XCP-Gateway Series

CSM's XCP-Gateway Series protocol converters were specially developed for CSM EtherCAT® measurement modules and for measurement tasks with multiple measurement channels and high measurement data rates. The XCP-Gateway is available in "Basic" and "pro" versions. The "pro" version has two CAN interfaces via which CAN-based CSM measurement modules can be connected and integrated into the XCP-on-Ethernet measurement data protocol. In the "pro" version, temperature data from the HV Breakout Modules can also be transferred directly via EtherCAT®.



The ECAT interface cable K420.1, the ECAT connection cable K400.1 and the CAN connection cable K70 were used as accessories in this example.

CSM provides you with comprehensive complete packages consisting of measuring modules, sensors, connecting cables and software - customized to your individual needs.

Further information on our products are available on our website at [www.csm.de](http://www.csm.de) or via e-mail [sales@csm.de](mailto:sales@csm.de).



**CSM GmbH Headquarters** (Germany)

Raiffeisenstraße 36 • 70794 Filderstadt  
☎ +49 711-77 96 40 ✉ sales@csm.de

**CSM Office Southern Europe** (France, Italy)

Site d'Archamps  
178, rue des Frères Lumière • Immeuble Alliance – Entrée A  
74160 Archamps France  
☎ +33 450-95 86 44 ✉ info@csm-produits.fr

**CSM Products, Inc. USA** (USA, Canada, Mexico)

1920 Opdyke Court, Suite 200 • Auburn Hills, MI 48326  
☎ +1 248 836-4995 ✉ sales@csmproductsinc.com

**CSM** (RoW)

Vector Informatik (China, Japan, Korea, India, Great Britain)  
ECM AB (Sweden)  
DATRON-TECHNOLOGY (Slovakia, Czech Republic)

Our partners guarantee you worldwide availability.  
Feel free to contact us.