

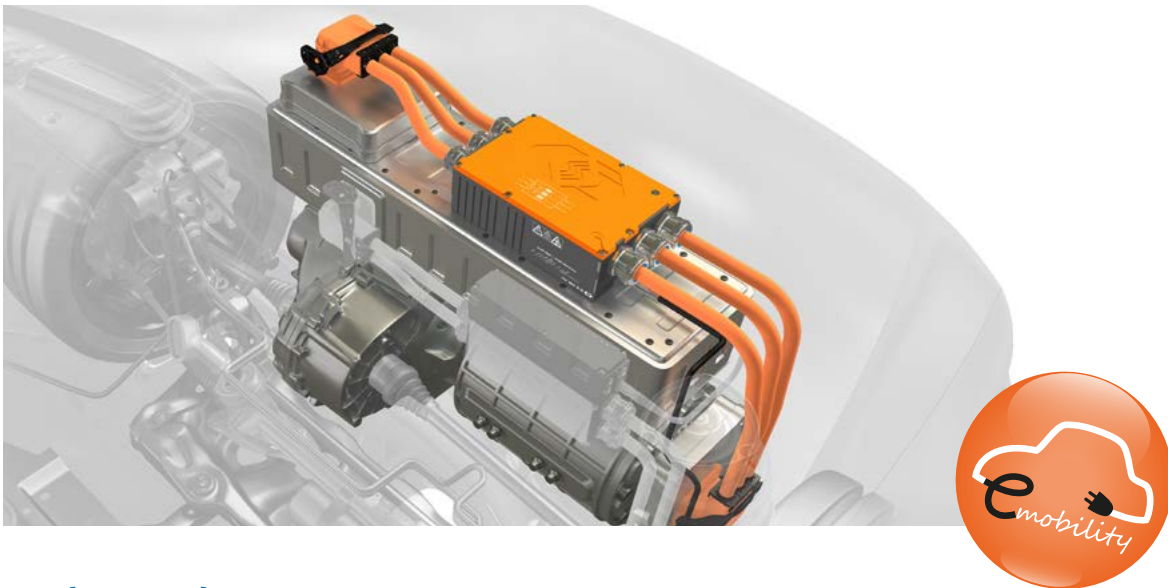

## High-Voltage Power Measurement

### Real-time efficiency measurement on inverter and electric motor

The range electric vehicles can travel before recharging must be increased for a widespread conversion to eMobility. One prerequisite for this is the further optimization of the energy flow in the electric powertrain. The following example shows how to measure accurate real-time efficiency with the Vector CSM E-Mobility Measurement System.



### Background

 Range is an important factor in increasing the consumers' acceptance of electric vehicles, therefore the components of the electric powertrain must be optimized for maximum range per charge. The inverter plays an important part in this, because its function is to transfer as much energy as possible from the battery to the electric motor. The inverter transforms the DC current into three-phase AC current, and regulates the electric motor. During that process, some energy is lost due to PWM switching performance and waste heat.

The inverter also performs conversion in the opposite direction: during the braking process the electric motor acts as a generator of alternating current. This current is fed back to the battery as regeneration.

Therefore a fully optimized inverter is essential for maximized vehicle range. Therefore, measuring the

inverter's efficiency provides a means of evaluating and verifying modifications to the design or control software.

For electromobility, test benches are being expanded or rebuilt in order to be able to meet the new requirements. The design or construction of these test benches should be carried out cost-effectively. The measurement system used should be highly accurate and scalable, allowing for a wide range of applications. On the test bench, the complete drivetrain or individual components, such as inverters, are tested under different operating conditions and the performance is analyzed.

This example shows how the efficiency of the inverter and the associated electric motor can be measured in real time with the Vector CSM E-Mobility Measurement System.

## Challenge

 In order to detect the high currents and voltages before and after the inverter the measurements have to be performed synchronously with high data rates. For a precise power calculation, the measurement must be direct and phase accurate.

For comprehensive analysis other measurement values, such as temperatures in the inverter, have to be acquired synchronously in order to observe/capture the working thresholds of the device and

determine the efficiency at a given temperature. Ideally the measurement module should be installed close to the sensors, avoiding the electromagnetic interferences (EMI) associated with long cables.

With these electrical and thermal measurements being taken in a high-voltage environment, the technology used must also ensure high-voltage safety to protect the device under test, the measurement equipment, and the user.

## The CSM Measurement Solution

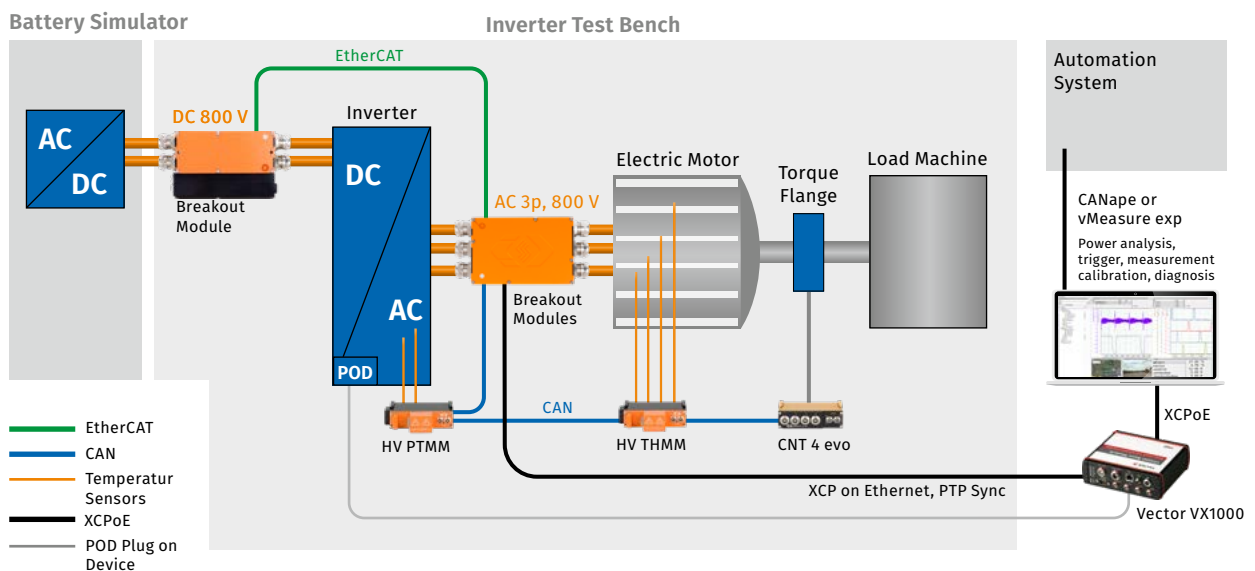



Fig. 1: Vector CSM E-Mobility Measurement System configuration for measuring powertrain efficiency

 High-voltage Breakout Modules can be used to measure single- or three-phase voltages and currents synchronously. This makes them the starting point for precise analysis, with the eMobilityAnalyzer function library for vMeasure exp software from Vector Informatik

- ▶ One CSM HV BM 1.2 is installed directly in the HV cables between the battery simulator and the inverter. The connection is made either via cable glands or via a PL500 plug-in system (variant HV BM 1.2C). The HV BM 1.2 measures single-phase DC current and voltages in separate HV+ and

HV- lines and transmits the data via EtherCAT® with a measurement data rate of up to 1 MHz. When equipped the appropriate connectors, simple plug-and-play installation is possible.

- ▶ A HV Breakout Module 3.3 is installed between the inverter and the electric motor. The HV cables are either fed into the housing through cable glands or connected via a PL300 plug-in system (with the HV BM 3.3C variant) and in this case secured via interlock. The 3W3P (3V3A) measuring circuit required for the phase-synchronous measurement of current and voltage is directly

integrated in the module. This avoids the need for complex cabling. The measurement data is transmitted via XCP-on-Ethernet at a data rate of up to 2 MHz per measured variable.



Fig. 2: HV breakout module 3.3 for three-phase measurement between inverter and electric motor.

- ▶ A high-voltage safe thermal module (HV PTMM) simultaneously detects relevant temperatures within the inverter.
- ▶ The XCP-Gateway option for the HV Breakout Module 3.3 provides an additional EtherCAT® and CAN interface in the module. This allows the HV BM 1.2 (via EtherCAT®) and the HV PTMM temperature measurement module (via CAN) to be connected directly to the HV BM 3.3. Via EtherCAT® the two HV Breakout Modules are synchronized more precisely than 1 μs.
- ▶ If the efficiency of the electric motor is to be determined, a counter measuring module (CNT 4 evo) is connected. The mechanical output power is recorded via a torque measuring flange and can be included as an input value to the efficiency calculation. This measuring module can also be connected to the CAN bus of the HV BM 3.3.

- ▶ A Vector VX1000 interface together with a Vector POD enables the acquisition of ECU-internal variables of the inverter. The measurement data from the VX1000 and the HV breakout modules are precisely synchronized using Precision Time Protocol (PTP) - IEEE 1588 standard.
- ▶ The Vector eMobilityAnalyzer function library for Vector's CANape or vMeasure exp software performs the desired real-time efficiency calculation.
- ▶ In the HV Breakout Modules 3.3 the power measurement circuit 3P3W (3 Phase 3 Wire) is already applied. This means that the phase currents ( $I_1, I_2, I_3$ ) are measured directly and the voltages between the phases ( $U_{12}, U_{23}, U_{31}$ ) are measured phase-synchronously. The sampling rate is 2 MS/s. All digital measured values of the CSM measurement modules are sent to the measuring computer via XCP. The eMobilityAnalyzer calculates all e-motor power values in real time such as active, apparent, and reactive power and the power factor.
- ▶ The inverter efficiency analysis is simply run in parallel with another function. It calculates all necessary parameters like input power and energy, output power and energy, power dissipation, energy loss, efficiency and frequency of the rotating field.

High-Voltage Power Measurement  
Real-time efficiency measurement on inverter and electric motor

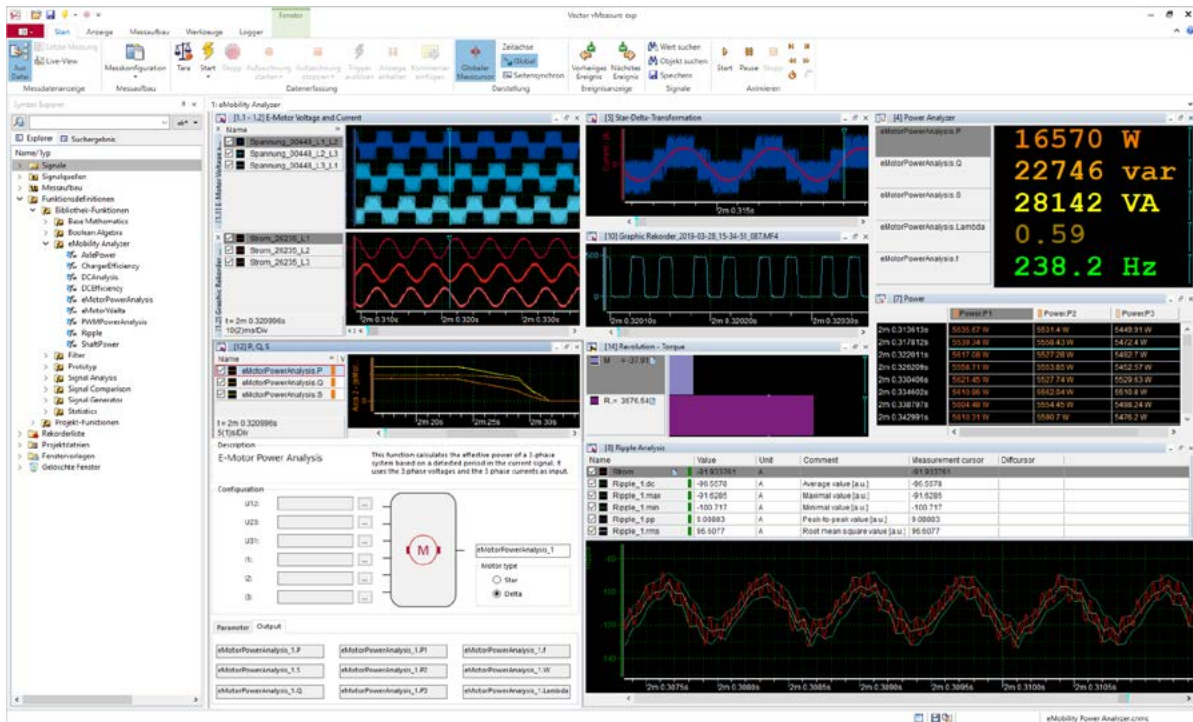

Fig. 3: Vector software vMeasure exp with opened function library eMobilityAnalyzer and power analysis.

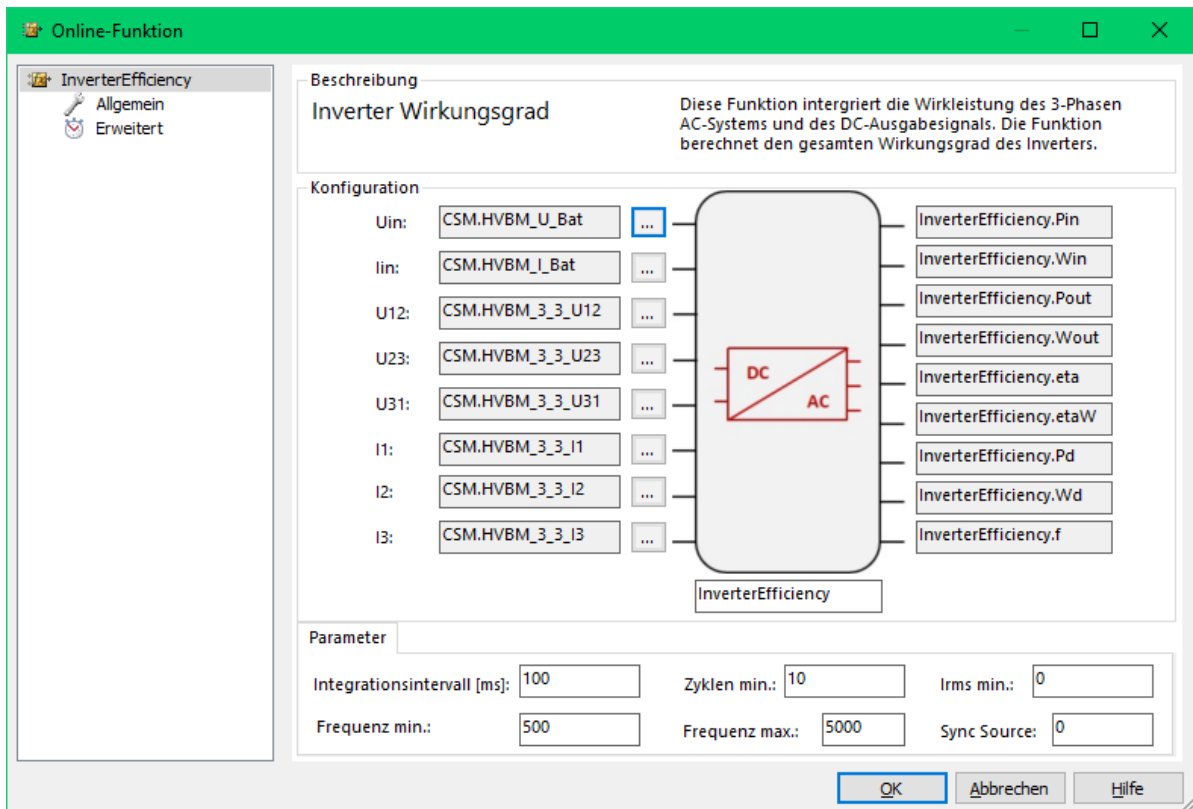

Fig. 4: Efficiency analysis with the eMobilityAnalyzer



Fig. 5: Detail of a test drive of an electric vehicle with a nominal electric power of 75 kW and instrumented CSM Vector E-Mobility Measurement System (see Fig. 1). From the velocity profile shown in the upper plot (white), one can see when the vehicle accelerates and when it decelerates. Accordingly, the current shown in red in the lower plot is positive or negative. The vehicle's power electronics work as an inverter when driving, with efficiencies of over 90% at higher loads, and as a charger when the engine is operated as a generator during recuperation. When charging, efficiencies of up to 90% are also achieved. It can be seen that at small currents during load changes, the efficiencies of both the inverter and charger become worse. The calculation of the efficiencies can be done directly during the measurement or afterwards. It is done with the evaluation function (see Fig. 4) included in Vector's eMobility Analyzer function package (included in CANape, vMeasure exp and vSignalizer). This evaluation function also determines the frequency of the motor currents, the rotating field.

## Benefits



The major advantage of the Vector CSM E-Mobility Measurement System lies in the ability to perform distributed measurements on the test bench or in a vehicle. Vector interfaces and software precisely process the parallel data acquisition from CSM measurement modules and ECUs. This simplifies cabling on the test bench, and allows the synchronized, simultaneous, and precise analysis of powertrain efficiency to optimize range and performance.

Via plug-in systems (HV BM 1.2C with PL500 and HV BM 3.3C with PL500), the HV Breakout Modules can be easily inserted into the measurement setup. Thus, DUTs can be exchanged quickly and different configurations can be tested.

In addition, further measuring modules can be connected directly to the HV BM 3.3 or HV BM3.3C, which further streamlines the measurement setup.

The acquisition of current and voltage values via simple breakout modules, and the real-time calculation of AC and DC power eliminates the cumbersome classic power analyzers and current converter systems.

The Vector CSM E-Mobility Measurement System ensures high-voltage safety from the sensor to data acquisition and is extremely easy to scale. This makes it simple to include additional measurement modules if required. The synchronicity is always guaranteed. The real-time efficiency calculation allows a quick and easy inspection and optimization of the components in the electric drive bench, and saves valuable time in development. In addition, the robust CSM measurement modules are also suitable for use in-vehicle. Values from the test bench can thus be easily compared with real conditions on the road.

## Featured Products

### HV Breakout Module - Type 1.1 | 1.2

CSM's HV Breakout Modules (BM) Type 1.1 and 1.2 have been specifically designed for safe measurement applications on high-voltage cables. Current and voltage are measured and the instantaneous power is calculated online in the module.

The HV Breakout Module 1.2 is available in two versions for connection via cable glands or PL500 plug-in system (HV BM 1.2C).



### HV Breakout-Module - Typ 3.3

The HV Breakout Module (BM) 3.3 has been specially designed for safe and precise three-phase measurement in HV cables. The inner conductor currents and outer conductor voltages are directly acquired and output 100% synchronously and phase-accurately via XCP-on-Ethernet.

The connection is made either via cable glands through which the HV cables are led into the module (HV BM 3.3) or via a PL300 plug-in system (HV BM 3.3C).



### HV PTMM 2

CSM's HV PTMM 2 measurement module with 2 measurement inputs in 4-wire technology for PT100 or PT1000 sensors was specially designed for precise temperature measurements in a high-voltage environment.



### CNT4 evo

CSM's CNT4 evo is a high-precision measurement module for measuring frequencies up to 300 kHz, for determining duty cycles or PWM signals, for determining period and pulse duration as well as up and down counting. Speeds can be recorded directly in the module and output as a value on the CAN bus. In addition, the time offset between adjacent channels can be measured.



CSM provides you with comprehensive complete packages consisting of measuring modules, sensors, connecting cables and software - customized to your individual needs.

Further information on our products are available on our website at [www.csm.de](http://www.csm.de) or via e-mail [sales@csm.de](mailto:sales@csm.de).



**CSM GmbH Headquarters** (Germany)

Raiffeisenstraße 36 • 70794 Filderstadt  
☎ +49 711-77 96 40 ✉ sales@csm.de

**CSM Office Southern Europe** (France, Italy)

Site d'Archamps  
178, rue des Frères Lumière • Immeuble Alliance – Entrée A  
74160 Archamps France  
☎ +33 450-95 86 44 ✉ info@csm-produits.fr

**CSM Products, Inc. USA** (USA, Canada, Mexico)

1920 Opdyke Court, Suite 200 • Auburn Hills, MI 48326  
☎ +1 248 836-4995 ✉ sales@csmproductsinc.com

**CSM** (RoW)

Vector Informatik (China, Japan, Korea, India, Great Britain)  
ECM AB (Sweden)  
DATRON-TECHNOLOGY (Slovakia, Czech Republic)

Our partners guarantee you worldwide availability.  
Feel free to contact us.